



RSG 482

Recurrent Surge Generator



All impulse circuit components may be adjusted in steps. The impulse shape can thus be fine-tuned within a wide range. Additional capacitors and resistors can be connected externally to permit operation with larger impulse capacitances and other resistance values. The peak value of the impulse voltage is stabilised and continuously adjustable. The voltage impulse may be chopped internally within broad limits. The unit also features a continuously adjustable oscilloscope trigger delay which may be set from trigger delay through zero to pre trigger.

DESIGN

The RSG 482 is a bench-top model which can also be mounted into 19" racks. All input and output jacks are located at the rear panel of the unit. All controls are arranged on the front panel for easy access.

APPLICATIONS

Recurrent Surge Generator 482 is a low voltage equivalent, with one stage only, of a high voltage impulse generator. Its wide range of applications includes the testing of models, the study of voltage distribution in high voltage windings during impulse voltage stresses and the predetermination of the circuit parameters of impulse test plants. Tests can be performed quickly and reliably without endangering personnel. All impulse circuit elements and, therefore, all impulse forms may be varied within broad limits with selector knobs. Due to the repetition frequency of 25 Hz, the voltage impulse may be observed and evaluated on any oscilloscope as a standing image.

The unit is especially suitable for:

- Investigating the impulse voltage distribution in winding models of machines, transformers, reactors and instrument transformers
- Predetermining impulse circuit data, for instance the value of the front resistance of an impulse generator, which can be performed by connecting the actual test object
- Non-destructive testing of windings in dry state and under various impulse voltage conditions
- Insulation fault localisation in windings
- Investigating transfer characteristics of measuring systems
- Transient wave measurement in cables and models
- Training and experimentation in laboratories of technical colleges and electro technical institutes

BASIC DIAGRAM

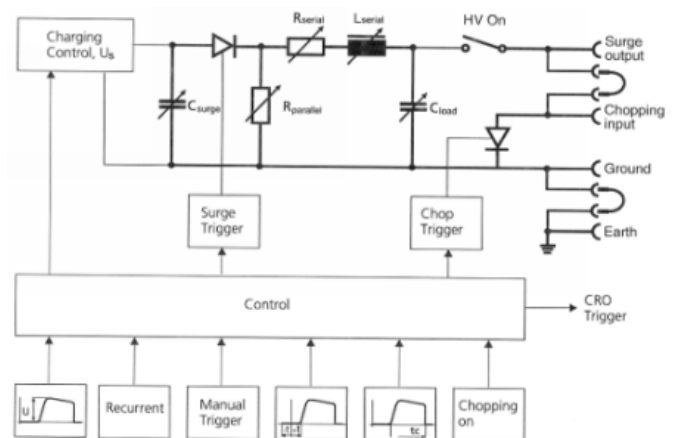
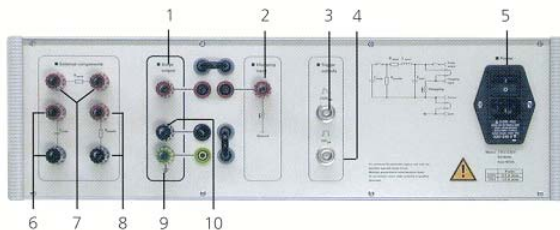

Figure 5

OPERATING ARRANGEMENT



- 1 Output voltage adjustment
- 2 CRO trigger adjustment
- 3 Chopping time adjustment
- 4 R_p (tail resistor) selector knob
- 5 R_s (front resistor) selector knob
- 6 L (series inductance) selector knob
- 7 C_L (load capacitance) selector knob
- 8 C_s (imp. capacitance) selector knob
- 9 Chopping ON/OFF
- 10 Recurrent triggering
- 11 Manual triggering
- 12 Mains switch



- 1 Impulse voltage output
- 2 Chopping circuit input
- 3 Oscilloscope triggering +180 V
- 4 Oscilloscope triggering +7.5 V
- 5 Mains input
- 6 C_s external impulse capacitance
- 7 R_s external front resistor
- 8 R_p external tail resistor
- 9 Grounding terminal
- 10 Common

OPERATION

The principle of operation of the recurrent surge generator is shown in Figure 5. The voltage is stabilised via the charging control circuit. The firing and chopping times are adjusted with the two thyristors „surge" and „chop" in the timing control circuit.

The entire event can be recorded with an oscilloscope as a stationary image and moved along the time base with the aid of the adjustable CRO trigger signal. This CRO trigger signal is available at BNC jacks with two different voltage levels. By rotating the impulse circuit component selector switches C_s , R_s , L , R_p , C_L , the operator can vary the impulse shape. The impulse circuit is floating. A plug can be inserted in the rear panel to connect the common output to ground. The impulse generation sequence is repeated and synchronised with the mains frequency when the „push for recurrent" key is depressed. The impulse can also be triggered manually in a non-recurrent manner by pressing the „manual trigger" key. The chopping circuit is activated by pressing the „chopping on" key. The „chop" thyristor circuit may be disconnected from the impulse circuit by removing a bridge between the sockets [Rear 1 and 2] located at the rear panel. The C_s , R_p , and R_s selector switches are provided with an „External" position. In this position, additional impulse circuit elements can be connected to the respective universal terminals located at the rear panel. Combined tests with AC or DC voltages up to 90 V between Ground [Rear 9] and Common [Rear 10] (housing) are possible due to the floating output.

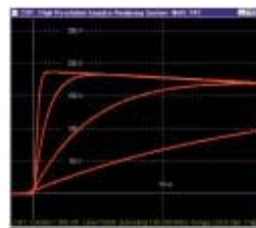

Figure 1

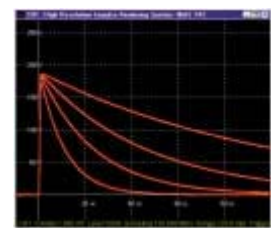

Figure 2

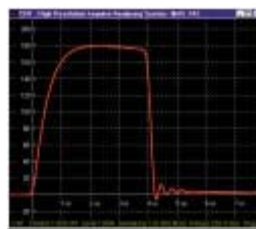

Figure 3

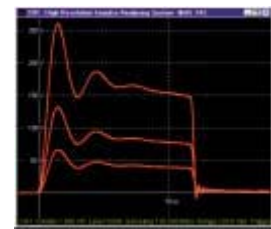

Figure 4

1. Front time selection by R_s adjustment
2. Time to half-value selection by R_p adjustment
3. Lightning impulse 1.2/50 μ s chopped after approx. 4 μ s
4. Chopped impulse at various charging voltages U
Overshoot simulated via selection of series inductance L

TECHNICAL DATA

Charging Voltage	0...500 V \pm 2%
Chopping delay	continuously 0.3 – 6.0 μ s
Chopping decay	approximately 100 ns
CRO Trigger delay	-5 μ s...+30 μ s
Impulse Capacitance Selector, C _s	4.7 nF, 6.8 nF, 10 nF, 22 nF, 33 nF, 47 nF, 68 nF, 100 nF, 220 nF, 330 nF, 470 nF, 680 nF, 1000 nF „Ext.“
Impulse Shape (front time), minimum	0.2 μ s
Impulse Shape (time to half value)	internal C _s : 0.3...3500 μ s external C _s : 0.3...9000 μ s
Inductance Selector, L	0 μ H, 10 μ H; 20 μ H; 30 μ H; 40 μ H; 50 μ H; 60 μ H; 70 μ H; 80 μ H; 90 μ H; 100 μ H.
Load Capacitance Selector, C _L	0.0 nF, 0.47 nF, 0.68 nF, 1 nF, 2.2 nF, 3.3 nF, 4.7 nF, 6.8 nF, 10 nF, 22 nF, 33 nF, 47 nF, 68 nF, 100 nF
Parallel Resistor Selector, R _p	10 Ω , 15 Ω , 22 Ω , 33 Ω , 47 Ω , 68 Ω , 100 Ω , 150 Ω , 220 Ω , 330 Ω , 470 Ω , 680 Ω , 1.0 k Ω , 1.5 k Ω , 2.2 k Ω , 3.3 k Ω , 4.7 k Ω , 6.8 k Ω , 10 k Ω , 15 k Ω , „Ext.“
Rated Voltage C _s EXT	0...500 V
Rated Voltage R _p EXT	0...500 V
Rated Voltage R _s EXT	0...500 V
Repetition Rate (using external C _s)	1.6 / 1.9 Hz (depends on power frequency 50/60 Hz)
Repetition Rate (using internal C _s)	25 / 30 Hz (depends on power frequency 50/60 Hz)
Series Resistor Selector R _s	3.3 Ω , 4.7 Ω , 6.8 Ω , 10 Ω , 15 Ω , 22 Ω , 33 Ω , 47 Ω , 68 Ω , 100 Ω , 150 Ω , 220 Ω , 330 Ω , 470 Ω , 680 Ω , 1.0 k Ω , 1.5 k Ω , 2.2 k Ω , 3.3 k Ω , 4.7 k Ω , „Ext.“
Trigger output:	180 V _{pp} 10 V _{pp} shape approximately 0.5 / 4 μ s
Permissible ambient temperature	0...45 °C
Permissible relative humidity	(non condensing) 0...95%
Size	19", 3 units high: approx. W: 50 cm, H: 15 cm, D: 40 cm
Weight	approximately 20 kg, net
Supply voltage	115 V / 230 V (50/60 Hz)

www.haefely.com

Europe, Asia, South & Central America, Australia
Haefely Test AG
Birsstrasse 300
4052 Basel
Switzerland
☎ + 41 61 373 4111
☎ + 41 61 373 4912
✉ sales@haefely.com

China (Sales & Service Office)
Haefely Test AG – Beijing Office
8-1-602, Fortune Street
No. 67, Chaoyang Road, Chaoyang District
Beijing, 100025
P. R. China
☎ + 86 10 8578 8099
☎ + 86 10 8578 9908
✉ sales@haefely.com.cn

North America
Hipotronics Inc.
1650 Route 22
PO Box 414
Brewster, NY 10509
USA
☎ + 1 845 279 3644
☎ + 1 845 279 2467
✉ sales@hipotronics.com

a brand of

HAEFELY 



Haefely is a subsidiary
of Hubbell Incorporated.

