



Load Cycle Test Set

Low Voltage, Current Test Set For Power Cable

■ The Hipotronics series of **High Current Load Cycle Test Systems** are designed to raise and control the temperature of a conductor or other low impedance electrical loop to simulate the current loading conditions found in electrical circuits. This heating is achieved by utilizing the test loop as the secondary winding of a current transformer for inductive heating. Measurement of the loop temperature is made by direct contact of a *K*-type thermocouple probe with the conductor of the test loop.

Our systems are offered as low voltage test systems or high voltage test systems. The low voltage test system utilizes one loop of the conductor passing through the desired number of CT carts to reach the necessary power level. For the high voltage test systems we again utilize the low voltage loop, but add a second loop through coupling carts which both the low and high voltage loops pass while isolating the low voltage and high voltage portions of the system. Once the high voltage loop is passed through the coupling carts the desired voltage is applied to the test loop with an AC high pot, while the desired current is generated from the Load Cycle Test Set. Additionally Impulse tests can be performed on the high voltage side of the test set up.



FEATURES

- ☑ Robust user friendly PLC based controls
- ☑ Temperature set controls
- ☑ Integrated chart recorder
- ☑ Optically isolated type *k* thermocouples
- ☑ Safety Interlocks
- ☑ Automatic and manual control of test sequences
- ☑ Timer for up to 365 days
- ☑ Zero start inter-lock
- ☑ Mobile CT carts with castors
- ☑ Updateable software
- ☑ Capacitive Compensation
- ☑ Main Power Breaker
- ☑ Future Expansion

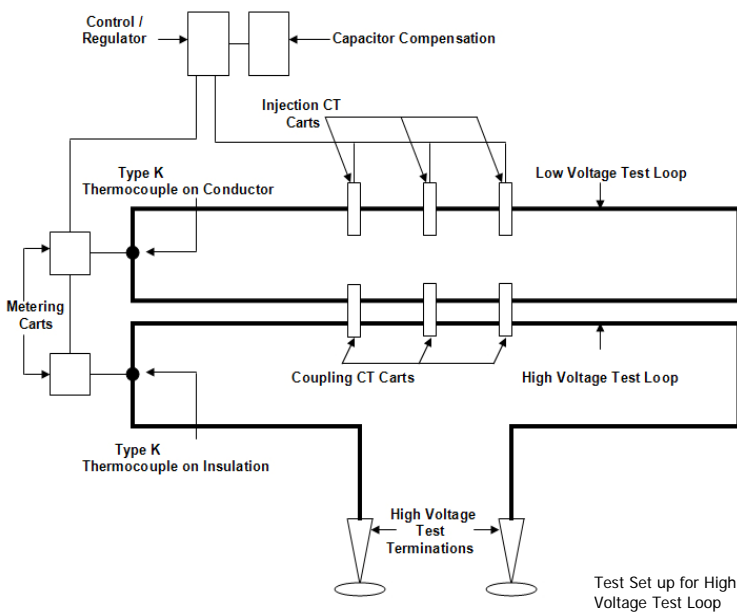

APPLICATIONS

Testing of insulating liquids in:

- ➔ Cable Testing

TECHNICAL SPECIFICATIONS

General

Input Voltage	xxx V, 1p, 50 or 60 Hz.
Output Voltage	0 ... 12.5, 15, 25, 30, 37.5, 45, 50, 60, 62.5, 75, 100, 120, 200, 240 V
Output Current	0 ... 2,000, 3,000, 4,000, 5,000 or 6000A
Temperature Meter Range	0 ... 199.9 degrees C
Temperature Meter Accuracy	± 1% (10 ... 90% of meter range)
Temperature Thermocouple	Type K (optically isolated)
Regulator Voltmeter Range	0 ... 1000V AC
Regulator Voltmeter Accuracy	± 2%
Regulator Output Current Range	0 ... 20 A
Regulator Current Meter Accuracy	± 2%
Recorder Width	100 mm

System Data

Number of CT carts	Seri es	Voltage (V) 60Hz	Voltage (V) 50Hz	Available current levels (A)
1	LV	15	12.5	
2	LV	30	25	2000
3	LV	45	37.5	3000
4	LV	60	50	4000
5	LV	75	62.5	5000
6	LV	90	75	6000
8	LV	120	100	
16	LV	240	200	

SCOPE OF SUPPLY

- Qty. 1 PLC control counsel with chart recorder
- Qty. 1 Voltage regulator with patented PVT.
- Qty. x Current Transformers (quantity depends on system voltage)
- Qty. 1 or 2 Metering carts with type k thermo couples (1 for low voltage testing, 2 for high voltage testing)
- Qty. 1 Instruction Manual

CONTROL PANEL

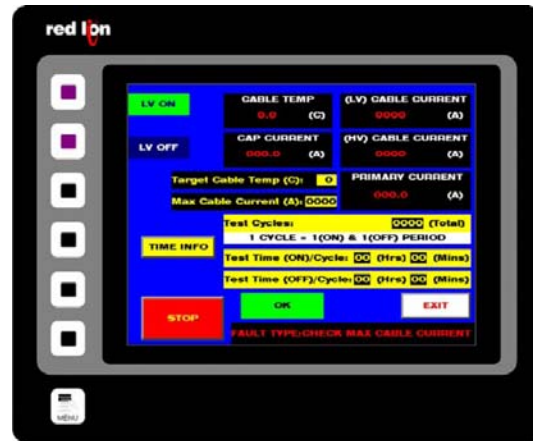

ORDERING INFORMATION

With the following information we can help determine the correct test set for any need.

- Cable Length
- Applicable Standards
- Type of insulation & cross-section
- Type of conductor & cross-section
- Temperature constraints

Example of System Model Number

LV30 – 5000 (30V, 5000A, 2 CT carts)

* Additional models and options are available upon request.

European Contact
Haefely Test AG
Lehenmattstrasse 353
CH-4028 Basel
Switzerland
☎ + 41 61 373 4111
☎ + 41 61 373 4912
✉ sales@haefely.com

Locate your local sales representative at
www.high-voltage-hubbell.com

USA Contact
Hipotronics Inc.
1650 Route 22
PO Box 414
Brewster, NY 10509 USA
☎ + 1 845 279 8091
☎ + 1 845 279 2467
✉ sales@hipotronics.com